

# Install guide GT5000

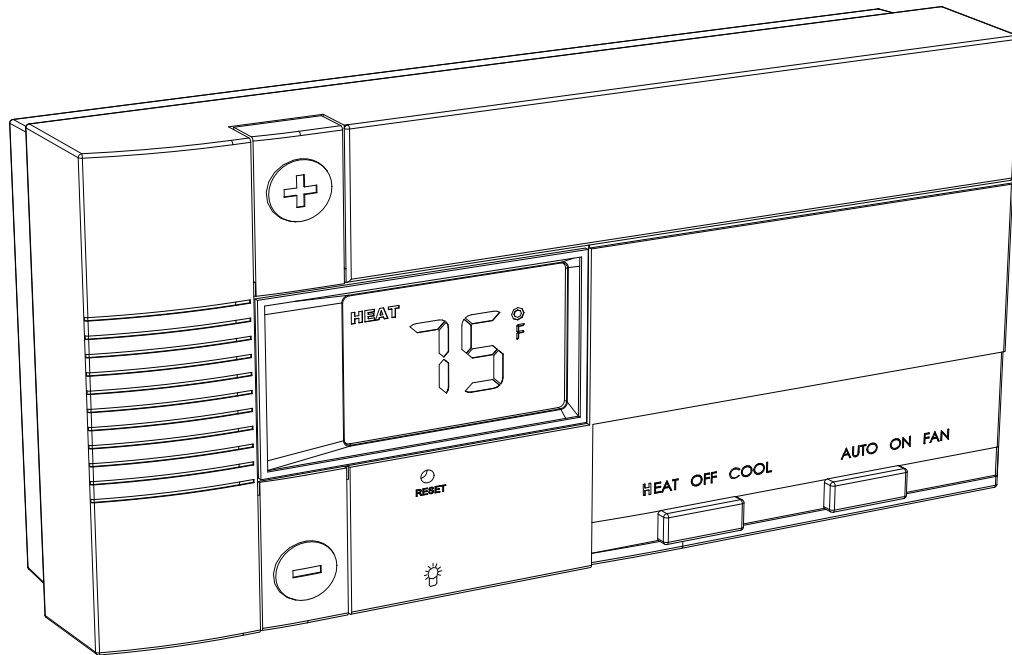

# Install guide GT5000

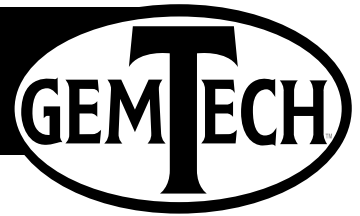

## Caution

To avoid electrical shock and to prevent damage to the furnace, air conditioner, and thermostat, disconnect the power supply before beginning work. This can be done at the circuit breaker, or at the appliance.

## Tools

You will need #1 Phillips screwdriver (small) and Drill with 3/16-in. (4.8mm) bit for this installation.

## 1 Location

- On replacement installations, mount the new thermostat in place of the old one if possible.
- On new installations, follow the guidelines listed below.
- Locate the thermostat on an inside wall, about 5 ft. (1.5m) above the floor, and in a room that is used often.
- Do not install it where there are unusual heating conditions, such as: in direct sunlight; near a lamp, radio, television, radiator register, or fireplace; near hot water pipes in a wall; near a stove on the other side of a wall.

- This thermostat does not require leveling.
- Do not locate in unusual cooling conditions, such as: on a wall separating an unheated room; or in a draft from a stairwell, door, or window.
- Do not locate in a damp area. This can lead to corrosion that will shorten thermostat life.
- Do not locate where air circulation is poor, such as: in a corner or an alcove; or behind an open door.
- Do not install the unit until all construction work and painting has been completed.

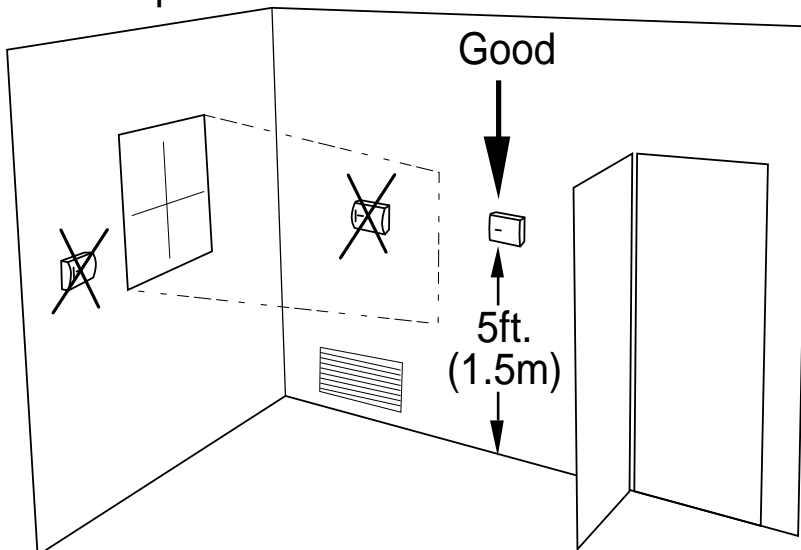

## CAUTION

- Your thermostat is a precise instrument.
- Please handle it with care.
- Turn off electricity to the appliance before installing or servicing thermostat or any part of the system. Do not turn electricity back on until work is completed.
- Do not short (jumper) across electric terminals at control on furnace or air conditioner to test the system.
- This will damage the thermostat and void your warranty.
- All wiring must conform to local codes and ordinances.
- This thermostat is designed for use with 24 volt AC and millivolt systems. The thermostat should be limited to a maximum of 1.0 amps; higher amperage may cause damage to the thermostat.

## 2 Remove old unit

- Switch electricity to the furnace and air conditioner OFF; then proceed with the following steps.
- Remove cover from old thermostat. Most are snap-on types and simply pull off. Some have locking screws on the side or front. These must be loosened. Note the letters printed near the terminals. Attach labels (enclosed) to each wire for identification.

**IMPORTANT : LABEL ALL WIRES BEFORE DISCONNECTING THEM!**

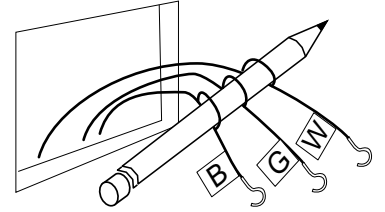

### Caution

Read instructions carefully before removing any wiring from existing thermostat. Wires must be labeled before they are removed. **THERE IS NO STANDARD COLOR CODE.** When removing wires from their terminals, ignore the color of the wires since these may not match the letters.

- Label the wires one at a time. **You must have all the wires labeled before you proceed.** With all wires labeled, remove them from the old unit.
- Make sure the wires **do not fall back inside** the wall. Wind them around a pencil to **keep them from falling.**
- Loosen all screws on the old thermostat and remove it from the wall.
- Fill wall opening with non-combustible insulation to prevent drafts.

### 3 Mount the GT5000

- Separate front from back of unit. Press up on the catch on bottom of thermostat and swing the body away from the base, lift up to remove the body from
- Hold the base against the wall, with the wires coming through the opening below the terminal block.
- Position the base for best appearance. Attach the base to the wall with the two screws provided.
- If you are mounting the base to sheet rock or if you are using the old mounting holes, use the plastic anchors provided. Drill a 3/16-in.(4.8mm) hole for the insert at each screw location, then mount the base.

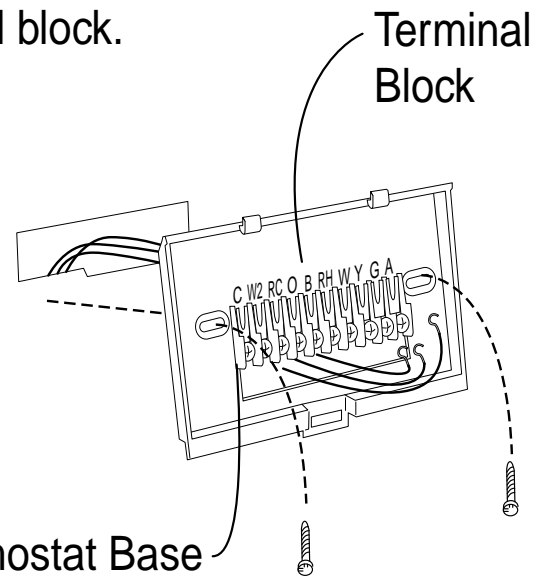
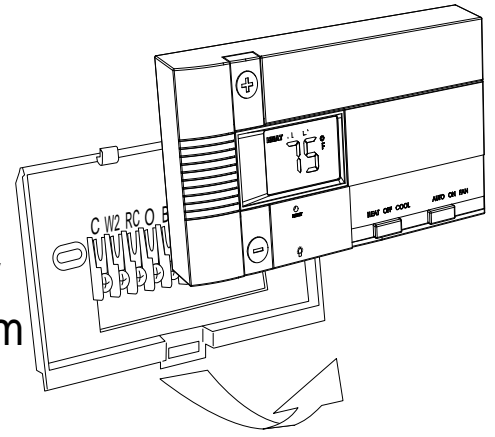

## 4 Gas-Electric Selection

REFER to the back of the Control Unit:

If you have Electric Heat or a *Heat Pump* you must place the Gas/Electric jumper in the ELECT position (thermostat controls the Fan).

If you have Gas Heat the Gas/Electric Jumper should be in the GAS position (furnace controls the Fan).

If your heating system has a second stage of conventional heat (W2) the thermostat will add the second stage heat source if the first stage does not make the target temp w/in 15 min.

The unit must be reset when any jumper is changed.

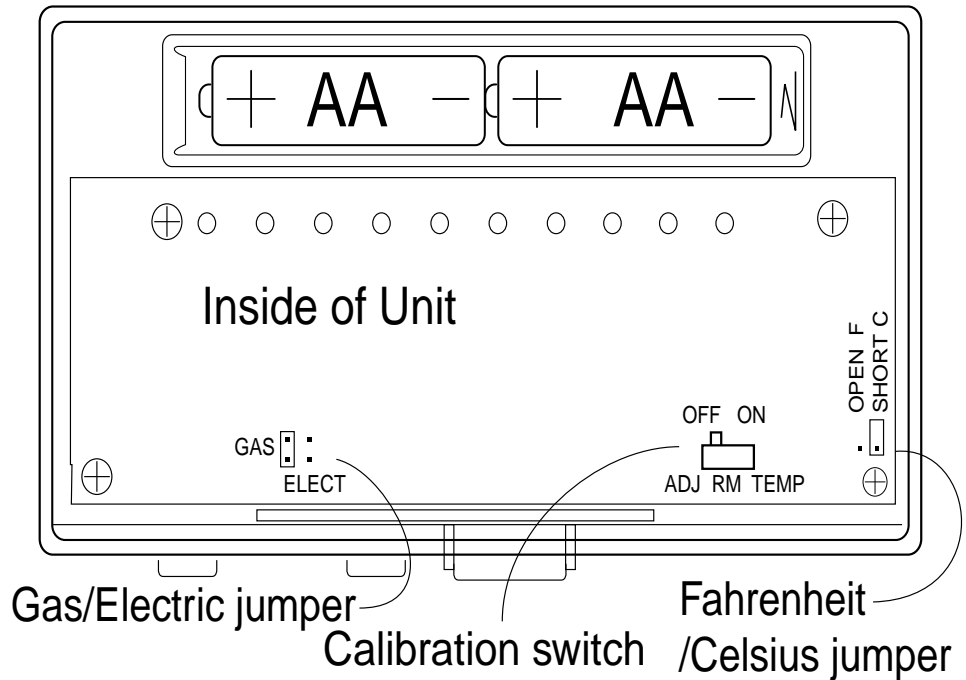

## 5 Install Batteries

The GT5000 requires batteries to operate your system and retain its programming in memory.

- Switch MODE switch to OFF and the FAN switch to AUTO.
- Insert 2 AA alkaline batteries according to the polarity noted in the compartment.
- Press the RESET button to clear the transient program memory. Initially, LCD display will go off.

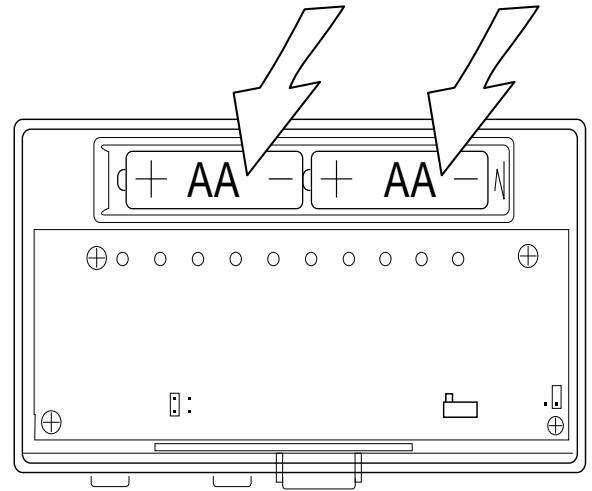

**NOTE:** Replace the batteries when this LOW battery indicator appears on the display or once a year. With batteries removed, you have approximately 30sec before your custom programming is lost. 

## 6 Power Options

Please be aware of the following power options

1) The GT5000 can run on batteries only. (2AA Alkaline)

The batteries will last well over 1 year. If the batteries are not replaced the thermostat will stop working.

2) The GT5000 can run on the C wire if available. (24 VAC ONLY)

As shown in the wiring diagrams, The C wire is the other side of the 24VAC heating transformer. If the C wire is used, the batteries are for AC power loss only and are not required.

## 7 Wire Connections

**Make sure your wires are labeled.** This is necessary to determine which step-by-step wiring diagram you should use. This may require you to find the 'other end' connection for each wire on your heating or air conditioning equipment and read the label there.

If you have a Zoned Heating/Cooling system with multiple thermostats, please refer to our website at [www.gemtech-thermostats.com](http://www.gemtech-thermostats.com) for installation notes.

### Before you Connect Wires

Please refer back to these guidelines for safe and secure wire connections.

- Take care **not to damage the labels** for each wire in handling.
- Strip insulation 3/8 in. (9.5mm) from wire ends.
- Connect labeled wires only to a terminal with corresponding letter.
- Bend the wire slightly, insert the wire under the contact plate and tighten the screw down onto the wire.

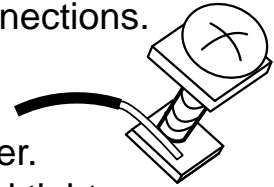

### What Wires Do You Have?

The Wire chart shows wire labels used on Gemtech thermostats. Please determine what wires you have and select the correct wiring diagram to "go to" on pages 9.

#### Caution

Do not allow wires to touch each other or parts on unit. Wires must be routed through the hole in the back plate, below the terminal block, or they will hit parts on the cover.

The Wire Chart below will help you determine the terminal connections you will use on your new thermostat. See chart section that applies to your heat/cool system.

	OLD THERMOSTAT	NEW THERMOSTAT	DESCRIPTION
<b>ONE Power Wire</b>	R or RH or 4 or V	RH or RC(leave jumper)	Power Wire
<b>TWO Power Wires</b>	RH or 4 or V RC or R	RH (remove jumper) RC (remove jumper)	Power Heat Power cool
<b>Control wires</b>	W or H Y or M G or F C or X W2 or H2 Y2	W Y G C W2 do not connect	Heat return Cool return (compressor) Fan return AC source for thermostat 2nd stage of heat 2nd stage of cool (n/a)
<b>HEAT PUMPS</b>	W2 E O (see note below) B (see note below)	W2  O B	Heat pump Aux heat Do not connect Dmpr/Chg-over (pwr in cool) Dmpr/Chg-over (pwr in heat)
<b>ZONED MOTOR VALVES</b>	5 or R 4 or W 6 or Y or B	RH W A	Power wire (pwr) Turn Valve on Turn Valve off
<b>ZONED SOLENOID VALVES</b>	R Y or B W	RH W A	Power wire (pwr) Turn Valve off Turn Valve on

Note: On a heat pump, if O and B are both present, connect O to O and tape off B.

For wiring support visit our website at [www.gemtech-thermostats.com](http://www.gemtech-thermostats.com)

NOTE: Wires marked with dotted line are optional.

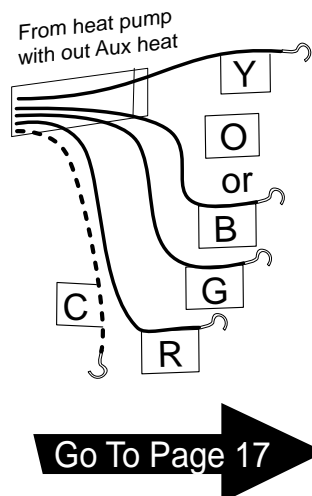
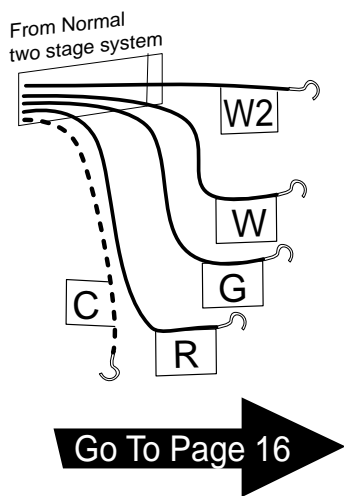
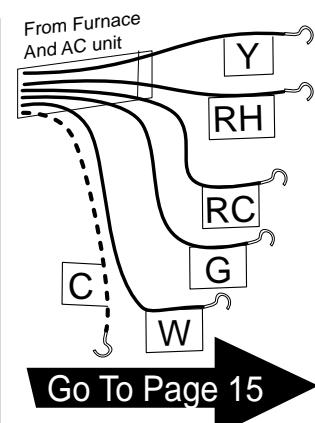
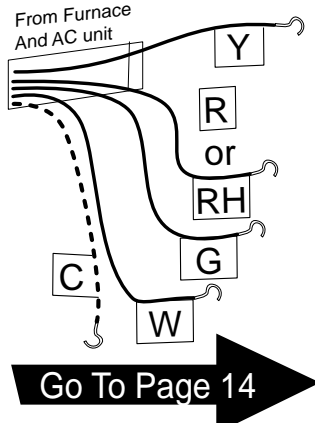
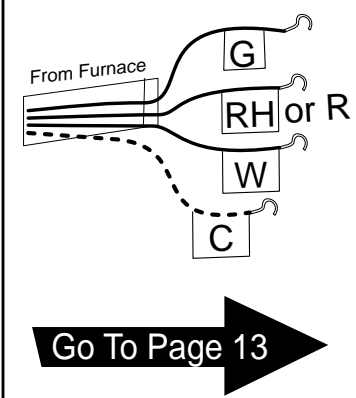
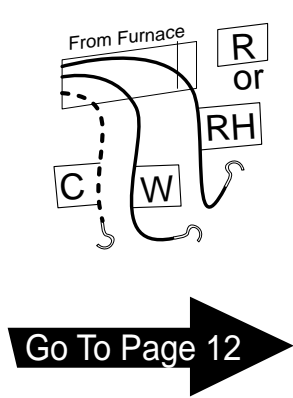

If you do not find the wiring information for your system try our website: [www.gemtech-thermostats.com](http://www.gemtech-thermostats.com)

## 7 Wire Connections cont

When you have finished connecting the wires attach control unit to wall unit. Hook the top of the body onto the base, swing the body down, and snap the body onto the base.

## 8 Check Unit

Follow these procedures to verify you have correctly installed the unit.

### To check HEAT mode:

- Set the mode switch to HEAT. Set the fan switch AUTO.
- Using the TEMP UP button raise the set point to 90deg.
- Allow the system 5 min to respond.
- Verify that heat is blowing from the system.
- Set the mode switch to OFF.

### To check COOL mode:

- Set the mode switch to COOL.
- Press the TEMP DOWN button to a temp 5° below room temperature.
- Allow the system 5 min to respond.
- Verify that cool air is blowing from the system.
- Set the mode switch to OFF.

### To check Fan:

- Switch mode to OFF during fan test.
- Switch the FAN switch to the ON position. Verify air is blowing from vents.
- After test, return fan switch to AUTO, and mode to HEAT or COOL.

Congratulations, you have successfully installed your unit. Please proceed to the OPERATING GUIDE to initialize the new thermostat. REMEMBER, Mode switch must be in HEAT or COOL to operate.

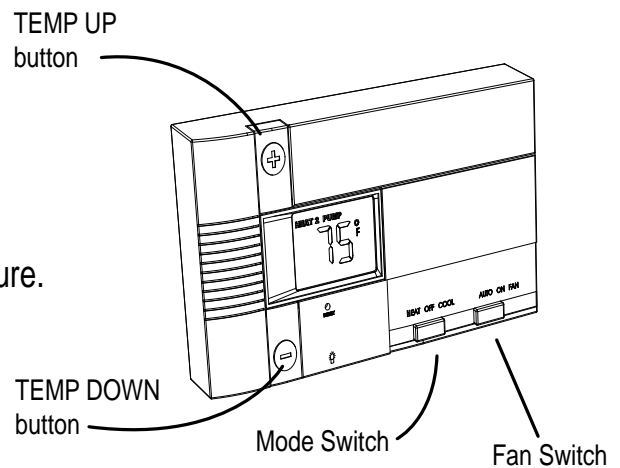
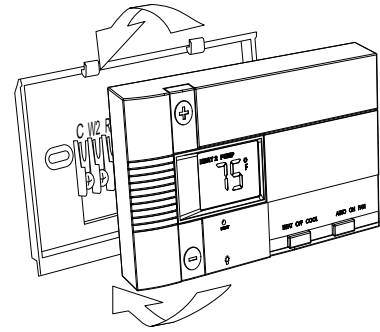

## GT5000 Features

The GT5000 can be used with most 24 volt gas, oil or electric heating and air conditioning systems, single-stage heat pumps or gas millivolt heating systems. It cannot be used with 120 volt heating systems or multistage heat pumps.

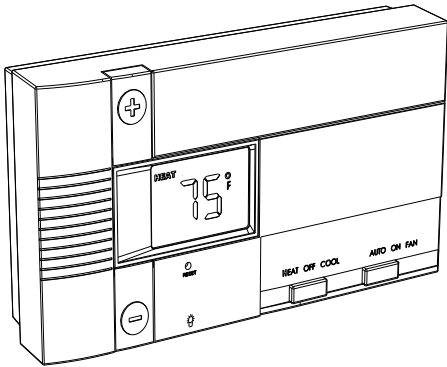

The GT5000 is digital. You can set your desired Heat and cool temperature set points directly on the Large LCD display.

You can easily override the set temperatures. 4-minute minimum off time in COOL protects your air conditioning system from being damaged.

Two "AA" batteries (not included) are used to retain your time and temperature programs, and to run the thermostat.

## 2 WIRE

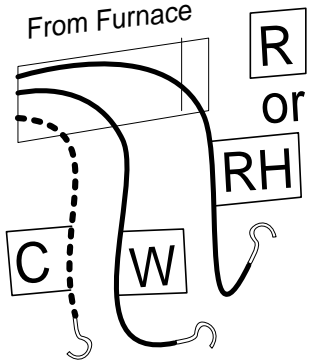

NOTE: Wires marked with the dotted line are optional.

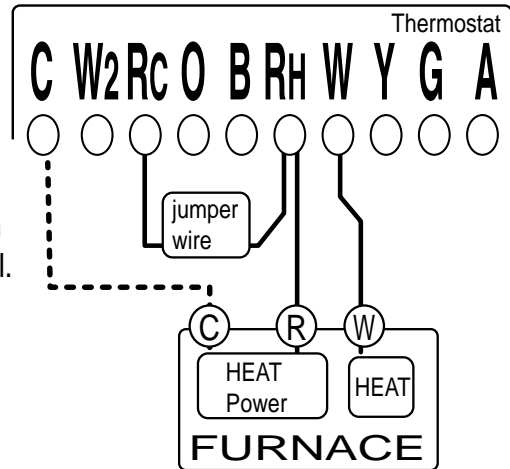

**STEP 1** - Connect the **R** (or RH) wire to the **RH** terminal on the thermostat. This connects to the Heater Power.

**STEP 2** - Connect the **W** wire to the **W** terminal on the thermostat. This connects the heater control line to the thermostat.

Your heater is now connected to the thermostat.



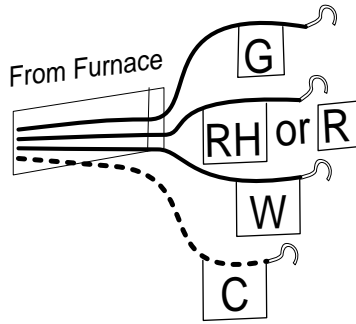

NOTE: Wires marked with the dotted line are optional.

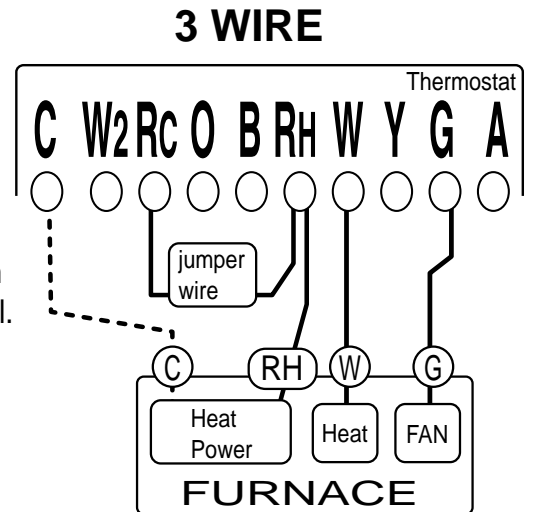

**STEP 1** - Connect the **R** (or **RH**) wire to the **RH** terminal on the thermostat. This connects to the Heater Power.

**STEP 2** - Connect the **W** wire to the **W** terminal on the thermostat. This connects the heater control line to the thermostat.

**STEP 3** - Connect the **G** wire to the **G** terminal on the thermostat. This connects the Fan to the thermostat.

Your system is now connected to the thermostat.

Go To Page 10

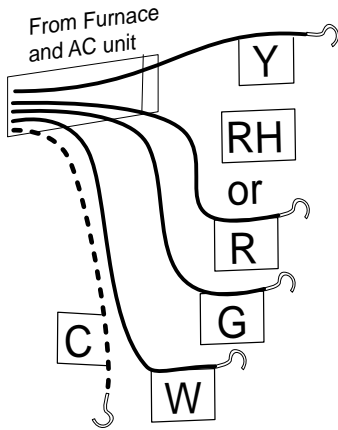

**STEP 1** - Connect the **Y** wire to the **Y** terminal on the thermostat. This connects to the Cooler compressor.

**STEP 2** - Connect the **RH** or **R** wire to the **RH** terminal on the thermostat. This connects the Heater/Cooler Power.

**STEP 3** - Connect the **W** wire to the **W** terminal on the thermostat. This connects to the heater control line.

**STEP 4** - Connect the **G** wire to the **G** terminal on the Thermostat. This connects to the Fan.

Your HVAC system is now connected to the thermostat.

**4 WIRE NON-HEAT PUMP**

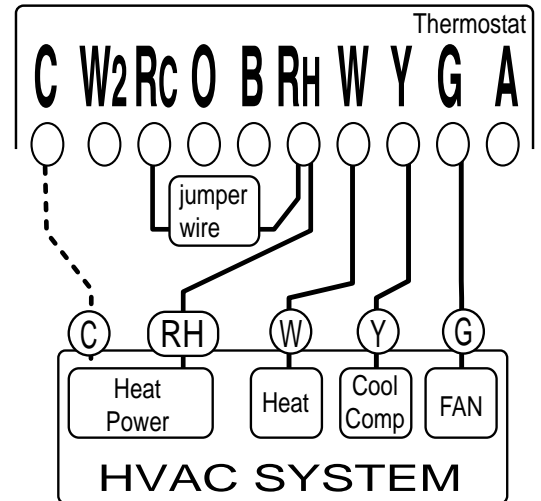

NOTE: Wires marked with the dotted line are optional.



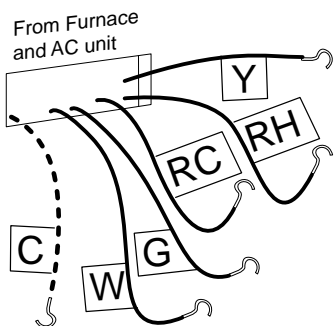

**STEP 1** - Remove the Jumper wire.

**STEP 2** - Connect the **Y** wire to the **Y** terminal on the thermostat. This connects to the Cooler compressor.

**STEP 3** - Connect the **RH** wire to the **RH** terminal on the thermostat. This connects to the Heater Power.

**STEP 4** - Connect the **RC** wire to the **RC** terminal on the thermostat. This connects to the Cooling Power.

**STEP 5** - Connect the **W** wire to the **W** terminal on the thermostat. This connects to the heater control line.

**STEP 6** - Connect the **G** wire to the **G** terminal on the Thermostat. This connects to the Fan.

**5 WIRE** NON-HEAT PUMP

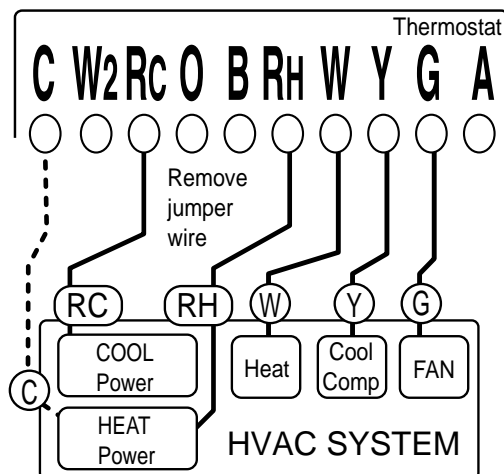

NOTE: Wires marked with the dotted line are optional.



Your HVAC system is now connected to the thermostat.

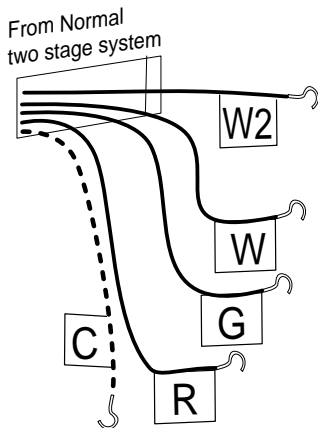

**STEP 1** - Connect the **G** wire to the **G** terminal on the thermostat. This connects the Fan.

**STEP 2** - Connect the **W** wire to the **W** terminal. This connects the 1st stage heat.

**STEP 3** - Connect the **W2** wire to the **W2** terminal. This connects the 2nd stage heat.

**STEP 4** - Connect the **R** wire to the **RH** terminal on the Thermostat. This connects to the 24vac power.

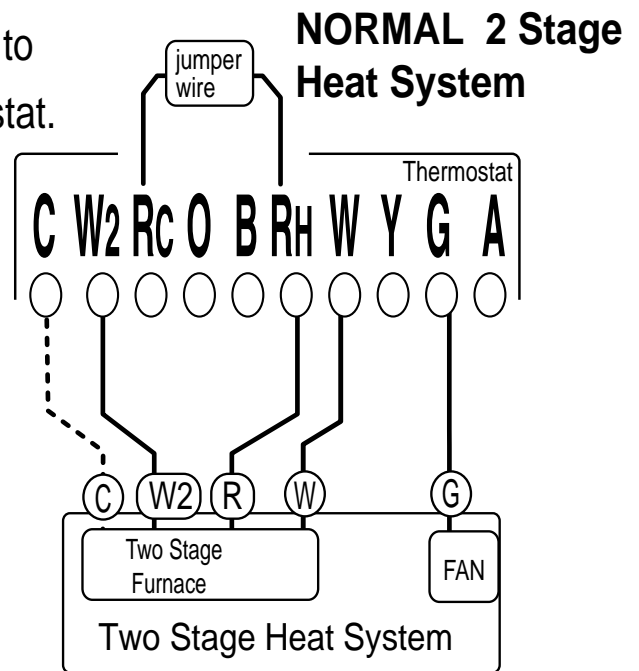

NOTE: Wires marked with the dotted line are optional.

Your HVAC system is now connected to the thermostat. (If the system also has AC, connect the **Y** wire to the **Y** terminal on the thermostat. You may also have a **RC** wire if so remove jumper wire between **RH** and **RC** and connect the **RC** wire to the **RC** terminal.)

Go To Page 10

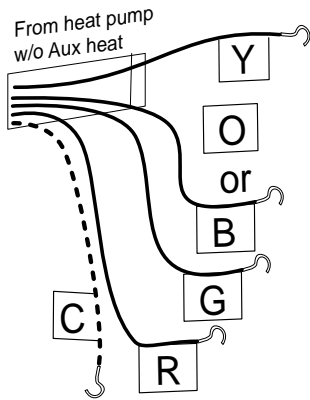

**STEP 1** - Connect the **G** wire to the **G** terminal on the thermostat.

This connects the Fan.

**STEP 2** - Add a jumper wire between **W** and **Y**.

**STEP 3** - Connect the **Y** wire to the **Y** terminal on the thermostat.

This connects the Compressor.

**STEP 4** - Connect the **O** or **B** wire to the **O** or **B** terminal on the thermostat. (If you have *both* **O** and **B** wires, use the **O** and tape off the **B**.) This connects the change over valve.

**STEP 5** - Connect the **R** wire to the **RC** terminal on the Thermostat. This connects to the 24vac power.

## HEAT PUMP w/o Auxiliary Heat

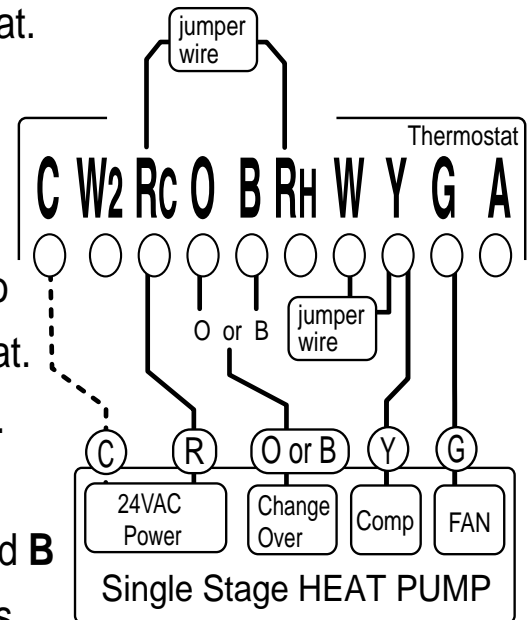

NOTE: Wires marked with the dotted line are optional.

Your HVAC system is now connected to the thermostat.

**Notes -**

---

---

---

---

---

---

---

---

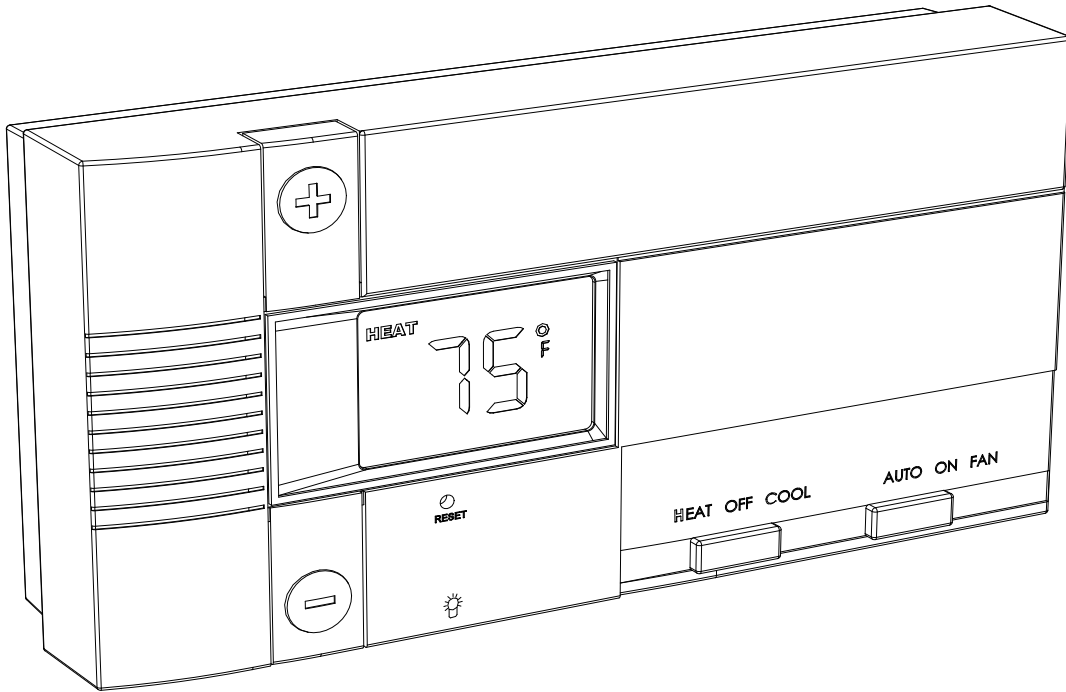

**Customer Support website [www.Gemtech-thermostats.com](http://www.Gemtech-thermostats.com)**

**1-507-011**